

Wall Mount Network Cabinet - WS Series

Designed for 19-inch standard network equipment ·
4 vertical rails · Welded structure ·



Key Features:

- ✓ Whole welded frame for stable and reliable structure
- ✓ Removable side panels for quick access
- ✓ Removable panels for cable entry on top, bottom and on the back
- ✓ Glass door with vented holes for ventilation
- ✓ Two 120 mm fan holes on top
- ✓ Front door can open left or right. Turning angle is over 180 deg.
- ✓ Easy mounting
- ✓ CE certificate

Standard:

ANSI/EIA RS-310-D, DIN41497 part 1, IEC297-2, DIN41494 part 7, GB/T3047.2-92

Loading Capacity:

60 kg

Degree of Protection:

IP20

Material:

SPCC cold rolled steel

Thickness:

Mounting profiles: 1.5mm, Side panels: 0.8mm, Others: 1.2mm

Surface Finish:

Degreasing, phosphoric, powder coated

W series explosion drawing

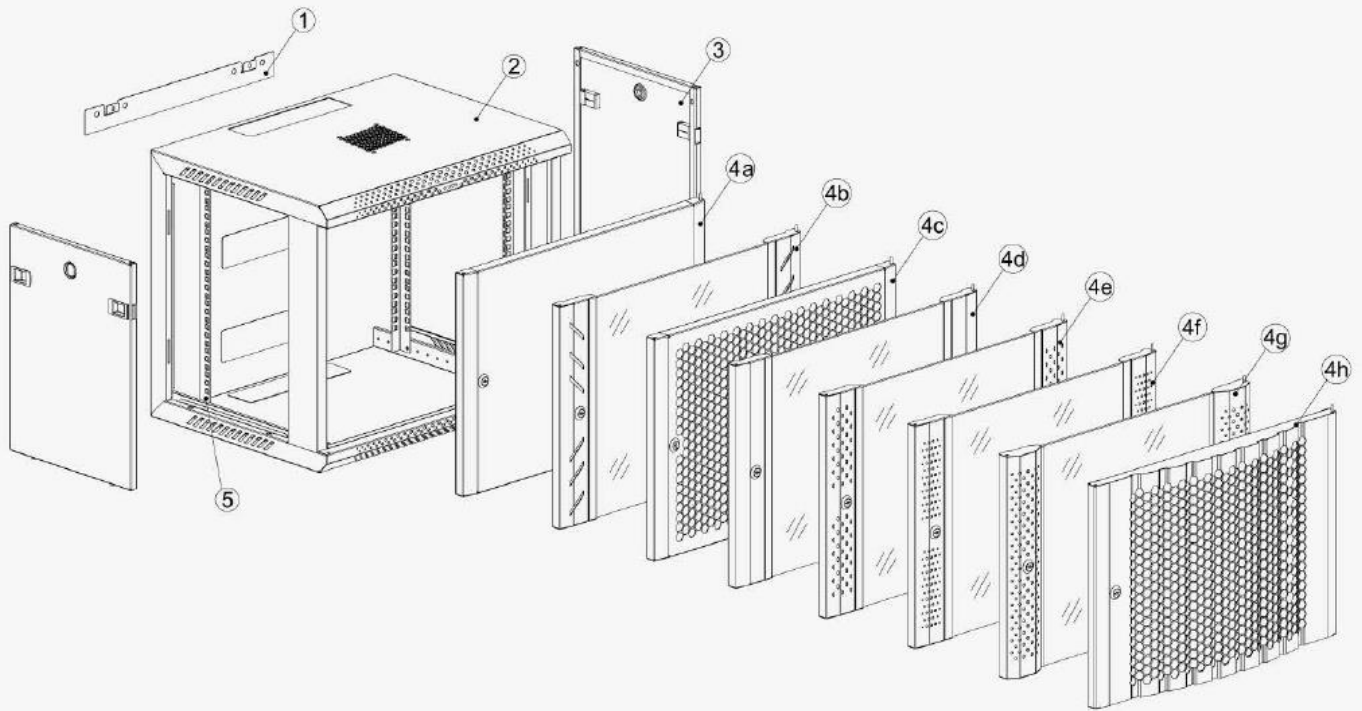

W series three-dimensional

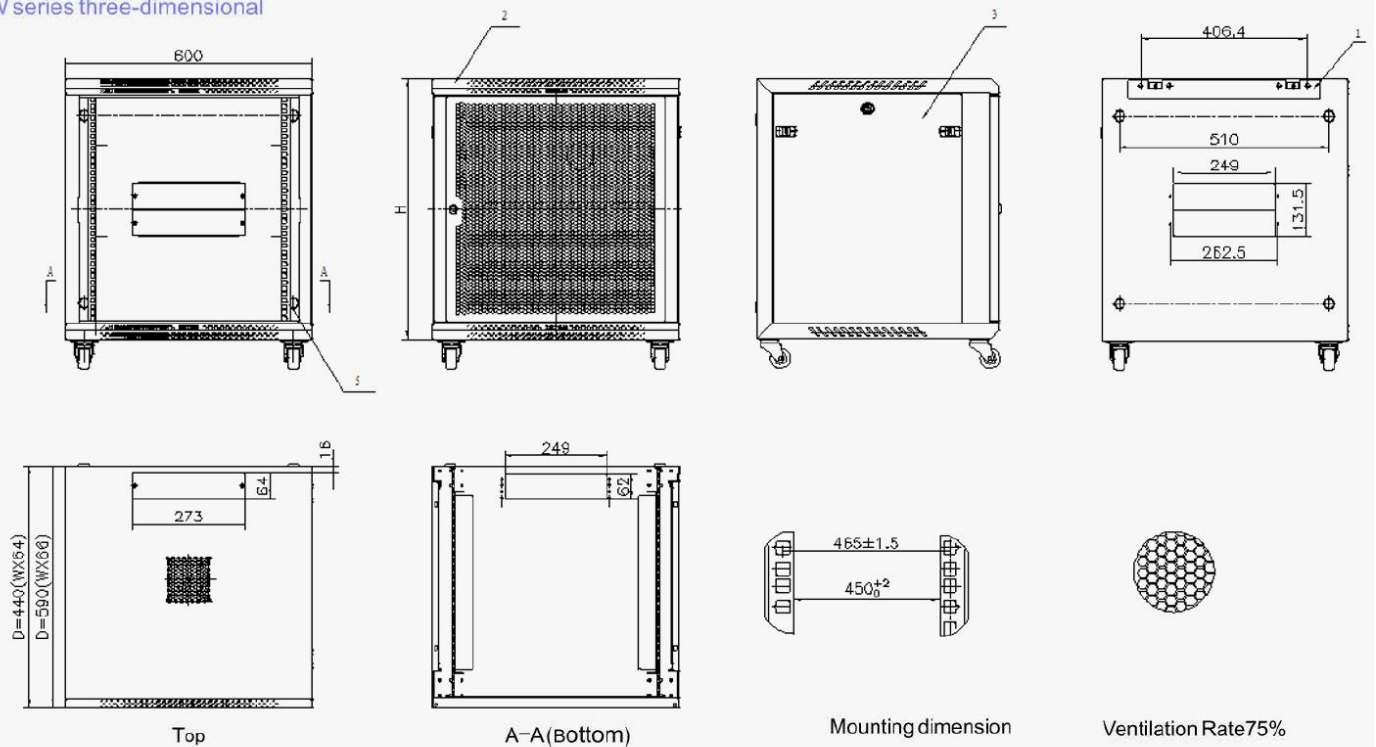

- 1. Mounting panel 2. Main body 3. Side panel 4a. W1 front door 4b. W2 front door 4c. W3 front door 4d. W4 front door
- 4e. W5 front door 4f. W6 front door 4g. WS front door 4h. WD front door 5. Mounting profile